

SYMMETRICAL COMPONENTS

1 & 2

Presented at the

28th Annual
HANDS ON RELAY SCHOOL
March 14 - 18, 2011

Washington State University
Pullman, Washington

Stephen E. Marx, P.E.
Bonneville Power Administration
Malin, Oregon

Introduction

The electrical power system normally operates in a balanced three-phase sinusoidal steady-state mode. However, there are certain situations that can cause unbalanced operations. The most severe of these would be a fault or short circuit. Examples may include a tree in contact with a conductor, a lightning strike, or downed power line.

In 1918, Dr. C. L. Fortescue wrote a paper entitled “Method of Symmetrical Coordinates Applied to the Solution of Polyphase Networks.” In the paper Dr. Fortescue described how arbitrary unbalanced 3-phase voltages (or currents) could be transformed into 3 sets of balanced 3-phase components, Fig I.1. He called these components “symmetrical components.” In the paper it is shown that unbalanced problems can be solved by the resolution of the currents and voltages into certain symmetrical relations.

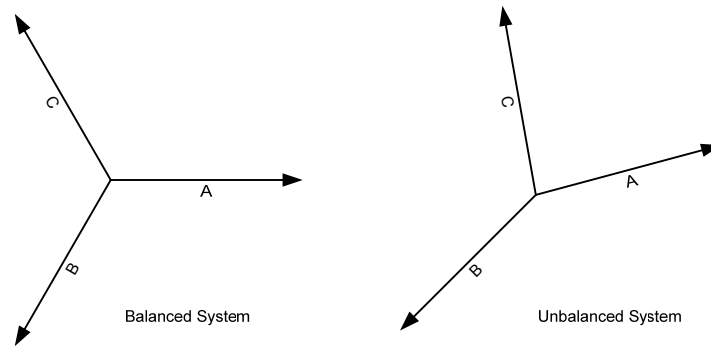

Fig I.1

By the method of symmetrical coordinates, a set of unbalanced voltages (or currents) may be resolved into systems of balanced voltages (or currents) equal in number to the number of phases involved. The symmetrical component method reduces the complexity in solving for electrical quantities during power system disturbances. These sequence components are known as positive, negative and zero sequence components, Fig I.2

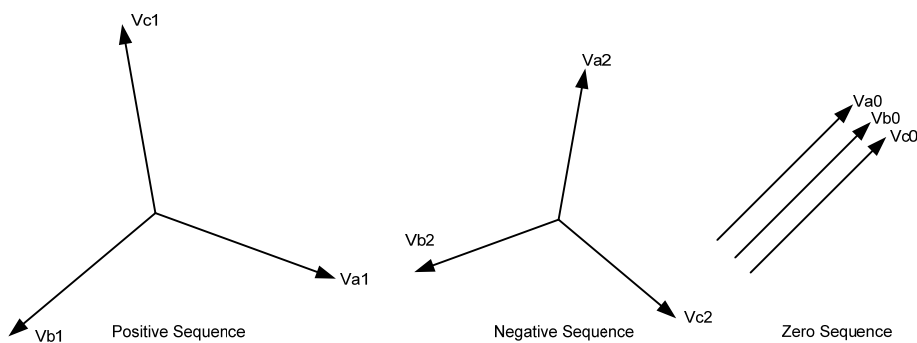

Fig I.2

The purpose of this paper is to explain symmetrical components and review complex algebra in order to manipulate the components. Knowledge of symmetrical components is important in performing mathematical calculations and understanding system faults. It is also valuable in analyzing faults and how they apply to relay operations.

1. Complex Numbers

The method of symmetrical components uses the commonly used mathematical solutions applied in ordinary alternating current problems. A working knowledge of the fundamentals of algebra of complex numbers is essential. Consequently this subject will be reviewed first.

Any complex number, such as $a + jb$, may be represented by a single point p , plotted on a Cartesian coordinates, in which a is the abscissa on the x axis of real quantities and b the ordinate on the y axis of imaginary quantities. This is illustrated in Fig. 1.1

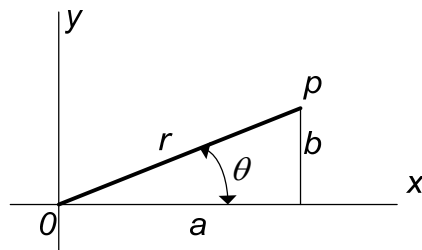

Fig. 1.1

Referring to Fig. 1.1, let r represent the length of the line connecting the point p to the origin and θ the angle measured from the x-axis to the line r . It can be observed that

$$a = r \cdot \cos \theta \quad (1.1)$$

$$b = r \cdot \sin \theta \quad (1.2)$$

2. Properties of Phasors

A vector is a mathematical quantity that has both a magnitude and direction. Many quantities in the power industry are vector quantities. The term phasor is used within the steady state alternating linear system. It is used to avoid confusion with spatial vectors: the angular position of the phasor represents position in time, not space. In this document, phasors will be used to document various ac voltages, currents and impedances.

A phasor quantity or phasor, provides information about not only the magnitude but also the direction or angle of the quantity. When using a compass and giving directions to a house, from a given location, a distance and direction must be provided. For example one could say that a house is 10 miles at an angle of 75 degrees (rotated in a clockwise direction from North) from where I am standing. Just as we don't say the other house is -10 miles away, the magnitude of

the phasor is always a positive, or rather the absolute value of the “length of the phasor.” Therefore giving directions in the opposite direction, one could say that a house is 10 miles at an angle of 255 degrees. The quantity could be a potential, current, watts, etc.

Phasors are written in polar form as

$$Y = |Y| \angle \theta \quad (2.1)$$

$$= |Y| \cos \theta + j|Y| \sin \theta \quad (2.2)$$

where Y is the phasor, $|Y|$ is the amplitude, magnitude or absolute value and θ is the phase angle or argument. Polar numbers are written with the magnitude followed by the \angle symbol to indicate angle, followed by the phase angle expressed in degrees. For example $Z = 110 \angle 90^\circ$. This would be read as 110 at an angle of 90 degrees. The rectangular form is easily produced by applying Eq. (2.2)

The phasor can be represented graphically as we have demonstrated in Fig. 1.1, with the real components coinciding with the x axis.

When multiplying two phasors it is best to have the phasor written in the polar form. The magnitudes are multiplied together and the phase angles are added together. Division, which is the inverse of multiplication, can be accomplished in a similar manner. In division the magnitudes are divided and the phase angle in the denominator is subtracted from the phase angle in the numerator.

Example 2.1

Multiply $A \cdot B$ where $A = 5 \angle 35^\circ$ and $B = 3 \angle 45^\circ$.

Solution

$$A \cdot B = 5 \angle 35^\circ \cdot 3 \angle 45^\circ = (5 \cdot 3) \angle (35^\circ + 45^\circ)$$

$$= 15 \angle 80^\circ$$

Example 2.2

Solve $\frac{C}{D}$ where $C = 15 \angle 35^\circ$ and $D = 3 \angle 50^\circ$.

Solution

$$\frac{C}{D} = \frac{15 \angle 35^\circ}{3 \angle 50^\circ} = \left(\frac{15}{3} \right) \angle (35^\circ - 50^\circ)$$

$$= 5 \angle -15^\circ$$

3. The *j* and *a* operator

Recall the operator *j*. In polar form, $j = 1\angle 90^\circ$. Multiplying by *j* has the effect of rotating a phasor 90° without affecting the magnitude.

Table 3.1 - Properties of the vector *j*

$1 = 1.0 + j0.0$	$j^3 = 1\angle 270^\circ = -j$
$j = 1\angle 90^\circ$	$-j = 1\angle -90^\circ$
$j^2 = 1\angle 180^\circ = -1$	

Example 3.1

Compute jR where $R = 10\angle 60^\circ$.

Solution

$$jR = 1\angle 90^\circ (10\angle 60^\circ)$$

$$= 10\angle 150^\circ$$

Notice that multiplication by the *j* operator rotated the Phasor \bar{R} by 90° , but did not change the magnitude. Refer to Fig. 3.1

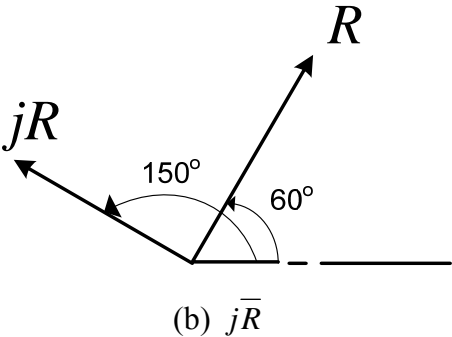
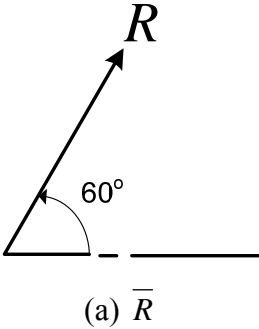

Fig. 3.1. *j* effects

In a similar manner the a operator is defined as unit vector at an angle of 120° , written as $a = 1\angle 120^\circ$. The operator a^2 , is also a unit vector at an angle of 240° , written $a^2 = 1\angle 240^\circ$.

Example 3.2

Compute aR where $R = 10\angle 60^\circ$.

Solution

$$\begin{aligned} aR &= 1\angle 120^\circ (10\angle 60^\circ) \\ &= 10\angle 180^\circ \end{aligned}$$

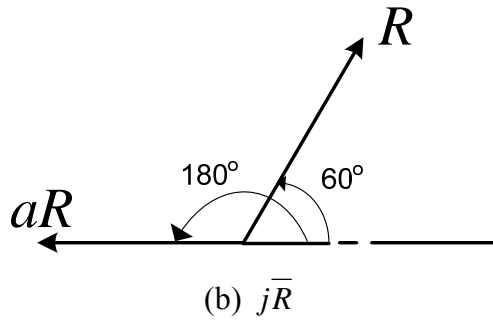
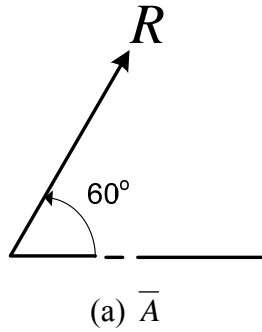

Fig. 3.2. a effects

Table 3.2 - Properties of the vector a

$$1 = 1.0 + j0.0$$

$$a = 1\angle 120^\circ$$

$$a^2 = 1\angle 240^\circ$$

$$a^3 = 1\angle 360^\circ = 1\angle 0^\circ$$

$$1 + a^2 + a = 0$$

$$a + a^2 = -1$$

$$1 + a = 1\angle 60^\circ$$

$$1 + a^2 = 1\angle -60^\circ$$

$$a - a^2 = j\sqrt{3}$$

$$a^2 - a = -j\sqrt{3}$$

$$1 - a = \sqrt{3}\angle -30^\circ$$

$$1 - a^2 = \sqrt{3}\angle 30^\circ$$

4. The three-phase System and the relationship of the $\sqrt{3}$

In a Wye connected system the voltage measured from line to line equals the square root of three, $\sqrt{3}$, times the voltage from line to neutral. See Fig. 4.1 and Eq. (4.1). The line current equals the phase current, see Eq. (4.2)

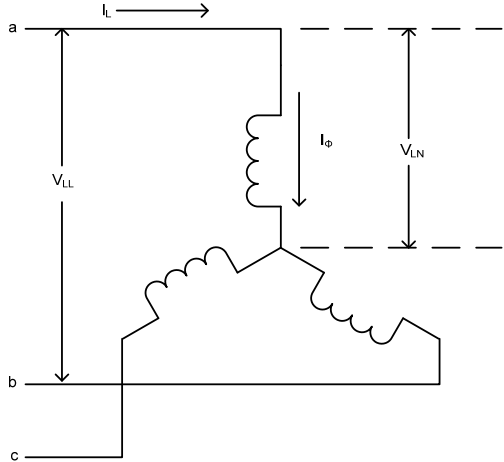

Fig. 4.1

$$V_{LL} = \sqrt{3}V_{LN} \tag{4.1}$$

$$I_L = I_\phi \tag{4.2}$$

In a Delta connected system the voltage measured from line to line equals the phase voltage. See Fig. 4.2 and Eq. (4.3). The line current will equal the square root of three, $\sqrt{3}$, times the phase current, see Eq. (4.4)

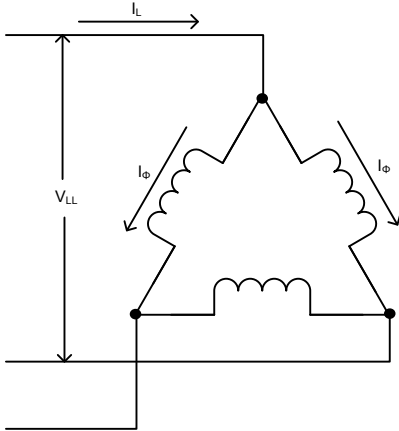

Fig. 4.2

$$V_{LL} = V_\phi \tag{4.3}$$

$$I_L = \sqrt{3}I_\phi \tag{4.4}$$

The power equation, for a three phase system, is

$$S = \sqrt{3}V_{LL}I_L \quad (4.5a)$$

$$P = \sqrt{3}V_{LL}I_L \cos\psi \quad (4.5b)$$

$$Q = \sqrt{3}V_{LL}I_L \sin\psi \quad (4.5c)$$

where S is the apparent power or complex power in volt-amperes (VA). P is the real power in Watts (W, kW, MW). Q is the reactive power in VARS (Vars, kVars, MVars).

5. The per-unit System

In many engineering situations it is useful to scale, or normalize, dimensioned quantities. This is commonly done in power system analysis. The standard method used is referred to as the *per-unit* system. Historically, this was done to simplify numerical calculations that were made by hand. Although this advantage is eliminated by the calculator, other advantages remain.

- Device parameters tend to fall into a relatively narrow range, making erroneous values conspicuous.
- Using this method all quantities are expressed as ratios of some base value or values.
- The *per-unit* equivalent impedance of any transformer is the same when referred to either the primary or the secondary side.
- The *per-unit* impedance of a transformer in a three-phase system is the same regardless of the type of winding connections (wye-delta, delta-wye, wye-wye, or delta-delta).
- The *per-unit* method is independent of voltage changes and phase shifts through transformers where the base voltages in the winding are proportional to the number of turns in the windings.

The *per-unit* system is simply a scaling method. The basic *per-unit* scaling equation is

$$per - unit = \frac{actual_value}{base_value} \quad (5.1)$$

The base value always has the same units as the actual value, forcing the *per-unit* value to be dimensionless. The base value is always a real number, whereas the actual value may be complex. The subscript *pu* will indicate a *per-unit* value. The subscript *base* will indicate a base value, and no subscript will indicate an actual value such as Amperes, Ohms, or Volts.

The first step in using *per-unit* is to select the base(s) for the system.

S_{base} = power base, in VA. Although in principle S_{base} may be selected arbitrarily, in practice it is typically chosen to be 100 MVA.

V_{base} = voltage base in V. Although in principle V_{base} is also arbitrary, in practice V_{base} is equal to the nominal line-to-line voltage. The term nominal means the value at which the system was designed to operate under normal balanced conditions.

From Eq. (4.5) it follows that the base power equation for a three-phase system is:

$$S_{3\Phi base} = \sqrt{3}V_{base} I_{base} \quad (5.2)$$

Solving for current:

$$I_{base} = \frac{S_{3\Phi base}}{\sqrt{3}V_{base}}$$

Because $S_{3\Phi base}$ can be written as kVA or MVA and voltage is usually expressed in kilo-volts, or kV, current can be written as:

$$I_{base} = \frac{kVA_{base}}{\sqrt{3}kV_{base}} \text{ amperes} \quad (5.3)$$

Solving for base impedance:

$$Z_{base} = \frac{V_{base}}{I_{base}} = \frac{V_{base}^2}{S_{base}}$$

$$Z_{base} = \frac{kV_{base}^2 \times 1000}{kVA_{base}} \text{ ohms} \quad (5.4a)$$

or

$$Z_{base} = \frac{kV_{base}^2}{MVA_{base}} \text{ ohms} \quad (5.4b)$$

Given the base values, and the actual values: $V = IZ$, then dividing by the base we are able to calculate the *pu* values

$$\frac{V}{V_{base}} = \frac{IZ}{I_{base}Z_{base}} \Rightarrow V_{pu} = I_{pu}Z_{pu}$$

After the base values have been selected or calculated, then the *per-unit* impedance values for system components can be calculated using Eq. (5.4b)

$$Z_{pu} = \frac{Z(\Omega)}{Z_{base}} = \left(\frac{MVA_{base}}{kV_{base}^2} \right) \cdot Z(\Omega) \quad (5.5a)$$

or

$$Z_{pu} = \left(\frac{kVA_{base}}{1000 \cdot kV_{base}^2} \right) \cdot Z(\Omega) \quad (5.5b)$$

It is also a common practice to express *per-unit* values as percentages (i.e. 1 pu = 100%). (Transformer impedances are typically given in % at the transformer MVA rating.) The conversion is simple

$$per - unit = \frac{percent - value}{100}$$

Then Eq. (5.5a) can be written as

$$\%Z = \frac{100MVA_{base} \cdot Z(\Omega)}{kV_{base}^2} = \frac{kVA_{base} Z(\Omega)}{10kV_{base}^2} \quad (5.6)$$

It is frequently necessary, particularly for impedance values, to convert from one (old) base to another (new) base. The conversion is accomplished by two successive application of Eq. (5.1), producing:

$$Z_{pu}^{new} = Z_{pu}^{old} \left(\frac{Z_{base}^{old}}{Z_{base}^{new}} \right)$$

Substituting for Z_{base}^{old} and Z_{base}^{new} and re-arranging the new impedance in *per-unit* equals:

$$Z_{pu}^{new} = Z_{pu}^{old} \left(\frac{kVA_{base}^{new}}{kVA_{base}^{old}} \right) \left(\frac{kV_{base}^{old}}{kV_{base}^{new}} \right)^2 \quad (5.7)$$

In most cases the turns ratio of the transformer is equivalent to the system voltages, and the equipment rated voltages are the same as the system voltages. This means that the voltage-squared ratio is unity. Then Eq. (5.9) reduces to

$$Z_{pu}^{new} = Z_{pu}^{old} \left(\frac{MVA_{base}^{new}}{MVA_{base}^{old}} \right) \quad (5.8)$$

Example 5.1

A system has $S_{base} = 100$ MVA, calculate the base current for

- a) $V_{base} = 230$ kV
- b) $V_{base} = 500$ kV

Solution

Using Eq. (5.3) $I_{base} = \frac{kVA_{base}}{\sqrt{3}kV_{base}}$ amperes

$$a) I_{base} = \frac{1000 \times 100}{\sqrt{3} \times 230} \text{ amperes} = 251A$$

$$b) I_{base} = \frac{1000 \times 100}{\sqrt{3} \times 500} \text{ amperes} = 115.5A$$

Example 5.2

A 900 MVA 525/241.5 autotransformer has a nameplate impedance of 10.14%

- a) Determine the impedance in ohms, referenced to the 525 kV side.
- b) Determine the impedance in ohms, referenced to the 241.5 kV side

Solution

First convert from % to *pu*.

$$Z_{pu} = \frac{Z\%}{100} = 0.1014$$

Arranging Eq. (5.5a) and solving for Z_{actual} gives

$$Z(\Omega) = Z_{pu} \frac{kV_{base}^2}{MVA_{base}}; \text{ therefore}$$

$$a) Z_{525kV} = 0.1014 \times \frac{525^2}{900} \\ = 31.05\Omega$$

$$b) Z_{241.5kV} = 0.1014 \times \frac{241.5^2}{900} \\ = 6.57\Omega$$

A check can be made to see if the high-side impedance to the low-side impedance equals the turns ratio squared.

$$\frac{31.05}{6.57} = 4.726 \qquad \left(\frac{525}{241.5} \right)^2 = 4.726$$

6. Sequence Networks

Refer to the basic three-phase system as shown in Fig. 6.1. There are four conductors to be considered: a , b , c and neutral n .

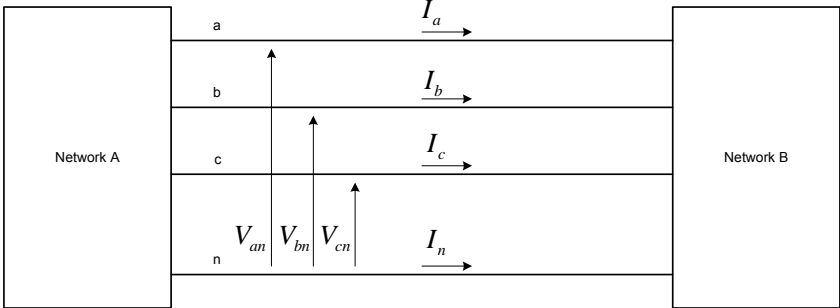

Fig. 6.1

The phase voltages, V_p , for the balanced 3Φ case with a phase sequence abc are

$$V_{an} = V_a = V_p \angle 0^\circ \tag{6.1a}$$

$$V_{bn} = V_b = V_p \angle -120^\circ \tag{6.1b}$$

$$V_{cn} = V_c = V_p \angle +120^\circ = V_p \angle -240^\circ \tag{6.1c}$$

The phase-phase voltages, V_{LL} , are written as

$$V_{ab} = V_a - V_b = V_{LL} \angle 30^\circ \tag{6.2a}$$

$$V_{bc} = V_b - V_c = V_{LL} \angle -90^\circ \tag{6.2b}$$

$$V_{ca} = V_c - V_a = V_{LL} \angle 150^\circ \tag{6.2c}$$

Equation (6.1) and (6.2) can be shown in phasor form in Fig. 6.2.

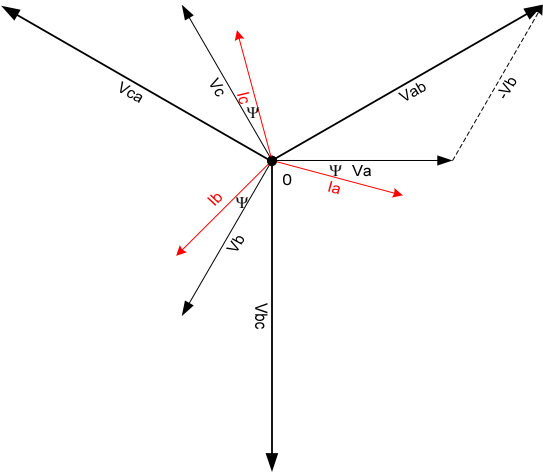

Fig. 6.2

There are two balanced configurations of impedance connections within a power system. For the wye case, as shown in Fig. 4.1, and with an impedance connection of $Z\angle\Psi$, the current can be calculated as

$$I_a = \frac{V}{Z_Y} = \frac{V_p}{Z_Y} \angle 0^\circ - \psi \quad (6.3)$$

Where Ψ is between -90° and $+90^\circ$. For Ψ greater than zero degrees the load would be inductive (I_a lags V_a). For ψ less than zero degrees the load would be capacitive (I_a leads V_a).

The phase currents in the balanced three-phase case are

$$I_a = I_p \angle 0^\circ - \psi \quad (6.4a)$$

$$I_b = I_p \angle -120^\circ - \psi \quad (6.4b)$$

$$I_c = I_p \angle -240^\circ - \psi \quad (6.4c)$$

See Fig. 6.2. for the phasor representation of the currents.

7. Symmetrical Components Systems

The electrical power system operates in a balanced three-phase sinusoidal operation. When a tree contacts a line, a lightning bolt strikes a conductor or two conductors swing into each other we call this a fault, or a fault on the line. When this occurs the system goes from a balanced condition to an unbalanced condition. In order to properly set the protective relays, it is necessary to calculate currents and voltages in the system under such unbalanced operating conditions.

In Dr. C. L. Fortescue's paper he described how symmetrical components can transform an unbalanced condition into symmetrical components, compute the system response by straight forward circuit analysis on simple circuit models, and transform the results back into original phase variables. When a short circuit fault occurs the result can be a set of unbalanced voltages and currents. The theory of symmetrical components resolves any set of unbalanced voltages or currents into three sets of symmetrical balanced phasors. These are known as positive, negative and zero sequence components. Fig. 7.1 shows balanced and unbalanced systems.

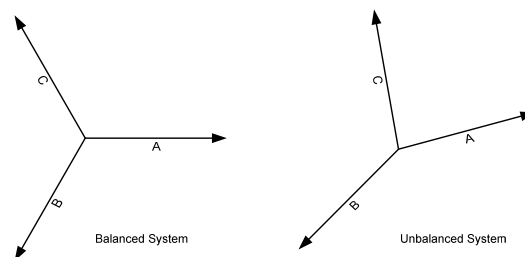

Fig. 7.1

Consider the symmetrical system of phasors in Fig. 7.2. Being balanced, the phasors have equal amplitudes and are displaced 120° relative to each other. By the definition of symmetrical components, \bar{V}_{b1} always lags \bar{V}_{a1} by a fixed angle of 120° and always has the same magnitude as \bar{V}_{a1} . Similarly \bar{V}_{c1} leads \bar{V}_{a1} by 120° . It follows then that

$$V_{a1} = V_{a1} \quad (7.1a)$$

$$V_{b1} = (1\angle 240^\circ)V_{a1} = a^2V_{a1} \quad (7.1b)$$

$$V_{c1} = (1\angle 120^\circ)V_{a1} = aV_{a1} \quad (7.1c)$$

Where the subscript (1) designates the positive sequence component. The system of phasors is called positive sequence because the order of the sequence of their maxima occur *abc*.

Similarly, in the negative and zero sequence components, we deduce

$$V_{a2} = V_{a2} \quad (7.2a)$$

$$V_{b2} = (1\angle 120^\circ)V_{a2} = aV_{a2} \quad (7.2b)$$

$$V_{c2} = (1\angle 240^\circ)V_{a2} = a^2V_{a2} \quad (7.2c)$$

$$V_{a0} = V_{a0} \quad (7.3a)$$

$$V_{b0} = V_{a0} \quad (7.3b)$$

$$V_{c0} = V_{a0} \quad (7.3c)$$

Where the subscript (2) designates the negative sequence component and subscript (0) designates zero sequence components. For the negative sequence phasors the order of sequence of the maxima occur *cba*, which is opposite to that of the positive sequence. The maxima of the instantaneous values for zero sequence occur simultaneously.

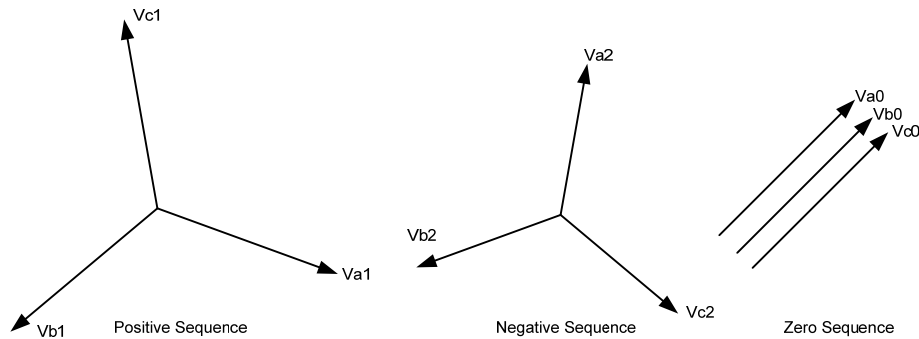

Fig.7.2

In all three systems of the symmetrical components, the subscripts denote the components in the different phases. The total voltage of any phase is then equal to the sum of the corresponding components of the different sequences in that phase. It is now possible to write our symmetrical

components in terms of three, namely, those referred to the a phase (refer to section 3 for a refresher on the a operator).

$$V_a = V_{a0} + V_{a1} + V_{a2} \quad (7.4a)$$

$$V_b = V_{b0} + V_{b1} + V_{b2} \quad (7.4b)$$

$$V_c = V_{c0} + V_{c1} + V_{c2} \quad (7.4c)$$

We may further simplify the notation as follows; define

$$V_0 = V_{a0} \quad (7.5a)$$

$$V_1 = V_{a1} \quad (7.5b)$$

$$V_2 = V_{a2} \quad (7.5c)$$

Substituting their equivalent values

$$V_a = V_0 + V_1 + V_2 \quad (7.6a)$$

$$V_b = V_0 + a^2V_1 + aV_2 \quad (7.6b)$$

$$V_c = V_0 + aV_1 + a^2V_2 \quad (7.6c)$$

These equations may be manipulated to solve for V_0 , V_1 , and V_2 in terms of V_a , V_b , and V_c .

$$V_0 = \frac{1}{3}(V_a + V_b + V_c) \quad (7.7a)$$

$$V_1 = \frac{1}{3}(V_a + aV_b + a^2V_c) \quad (7.7b)$$

$$V_2 = \frac{1}{3}(V_a + a^2V_b + aV_c) \quad (7.7c)$$

It follows then that the phase current are

$$I_a = I_0 + I_1 + I_2 \quad (7.8a)$$

$$I_b = I_0 + a^2I_1 + aI_2 \quad (7.8b)$$

$$I_c = I_0 + aI_1 + a^2I_2 \quad (7.8c)$$

The sequence currents are given by

$$I_0 = \frac{1}{3}(I_a + I_b + I_c) \quad (7.9a)$$

$$I_1 = \frac{1}{3}(I_a + aI_b + a^2I_c) \quad (7.9b)$$

$$I_2 = \frac{1}{3}(I_a + a^2I_b + aI_c) \quad (7.9c)$$

The unbalanced system is therefore defined in terms of three balanced systems. Eq. (7.6) may be used to convert phase voltages (or currents) to symmetrical component voltages (or currents) and vice versa [Eq. (7.7)].

Example 7.1

Given $V_a = 5\angle 53^\circ$, $V_b = 7\angle -164^\circ$, $V_c = 7\angle 105^\circ$, find the symmetrical components. The phase components are shown in the phasor form in Fig. 7.3

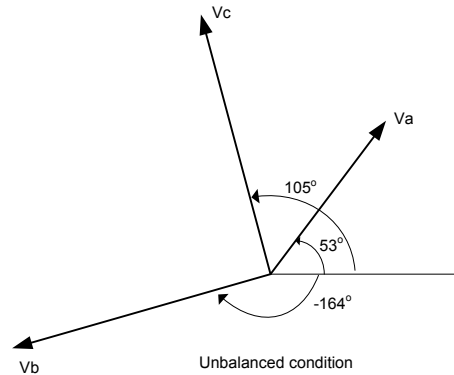

Fig. 7.3

Solution

Using Eq. (7.7)

Solve for the zero sequence component:

$$\begin{aligned} V_{a0} &= \frac{1}{3}(V_a + V_b + V_c) \\ &= \frac{1}{3}(5\angle 53^\circ + 7\angle -164^\circ + 7\angle 105^\circ) \\ &= 3.5\angle 122^\circ \end{aligned}$$

From Eq. (7.3b) and (7.3c)

$$V_{b0} = 3.5\angle 122^\circ$$

$$V_{c0} = 3.5\angle 122^\circ$$

Solve for the positive sequence component:

$$\begin{aligned} V_{a1} &= \frac{1}{3}(V_a + aV_b + a^2V_c) \\ &= \frac{1}{3}(5\angle 53^\circ + (1\angle 120^\circ \cdot 7\angle -164^\circ) + (1\angle 240^\circ \cdot 7\angle 105^\circ)) \\ &= 5.0\angle -10^\circ \end{aligned}$$

From Eq. (7.1b) and (7.1c)

$$V_{b1} = 5.0\angle -130^\circ$$

$$V_{c1} = 5.0\angle 110^\circ$$

Solve for the negative sequence component:

$$\begin{aligned} V_{a2} &= \frac{1}{3}(V_a + a^2V_b + aV_c) \\ &= \frac{1}{3}(5\angle 53^\circ + (1\angle 240^\circ \cdot 7\angle -164^\circ) + (1\angle 120^\circ \cdot 7\angle 105^\circ)) \\ &= 1.9\angle 92^\circ \end{aligned}$$

From Eq. (7.2b) and (7.2c)

$$V_{b2} = 1.9\angle -148^\circ$$

$$V_{c2} = 1.9\angle -28^\circ$$

The sequence components can be shown in phasor form in Fig. 7.4.

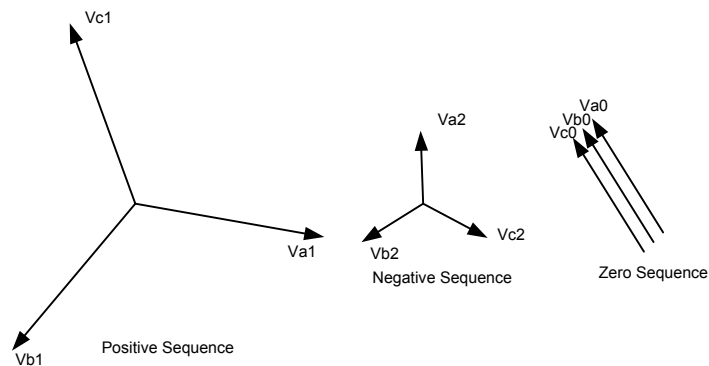

Fig. 7.4

Using Eq. (7.6) the phase voltages can be reconstructed from the sequence components.

Example 7.2

Given $V_0 = 3.5\angle 122^\circ$, $V_1 = 5.0\angle -10^\circ$, $V_2 = 1.9\angle 92^\circ$, find the phase sequence components. Shown in the phasor form in Fig. 7.4

Solution

Using Eq. (7.6)

Solve for the A-phase sequence component:

$$\begin{aligned} V_a &= V_0 + V_1 + V_2 \\ &= 3.5\angle 122^\circ + 5.0\angle -10^\circ + 1.9\angle 92^\circ \\ &= 5.0\angle 53^\circ \end{aligned}$$

Solve for the B-phase sequence component:

$$\begin{aligned}V_b &= V_0 + a^2V_1 + aV_2 \\ &= 3.5\angle 122^\circ + 5.0\angle -130^\circ + 1.9\angle -148^\circ \\ &= 7.0\angle -164^\circ\end{aligned}$$

Solve for the C-phase sequence component:

$$\begin{aligned}V_c &= V_0 + aV_1 + a^2V_2 \\ &= 3.5\angle 122^\circ + 5.0\angle 110^\circ + 1.9\angle -28^\circ \\ &= 7.0\angle 105^\circ\end{aligned}$$

This returns the original values given in Example 5.2.

This can be shown in phasor form in Fig. 7.5.

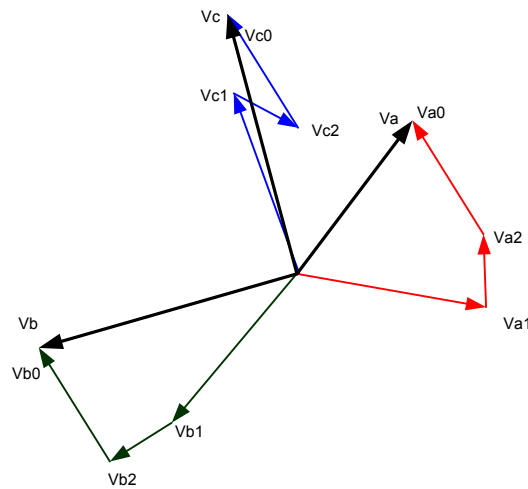

Fig. 7.5

Notice in Fig. 7.5 that by adding up the phasors from Fig. 7.4, that the original phase, Fig. 7.3 quantities are reconstructed.

8. *Balanced and Unbalanced Fault analysis*

Let's tie it together. Symmetrical components are used extensively for fault study calculations. In these calculations the positive, negative and zero sequence impedance networks are either given by the manufacturer or are calculated by the user using base voltages and base power for their system. Each of the sequence networks are then connected together in various ways to calculate fault currents and voltages depending upon the type of fault.

Given a system, represented in Fig. 8.1, we can construct general sequence equivalent circuits for the system. Such circuits are indicated in Fig. 8.2.

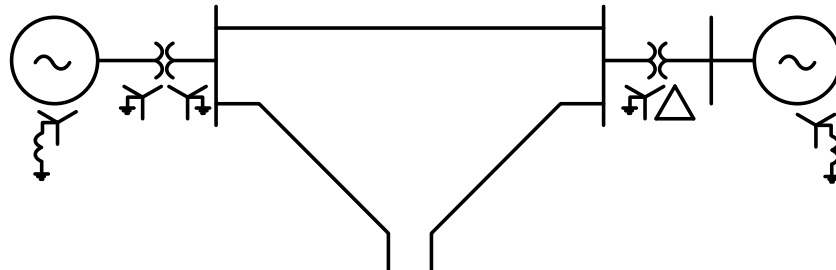

Fig. 8.1

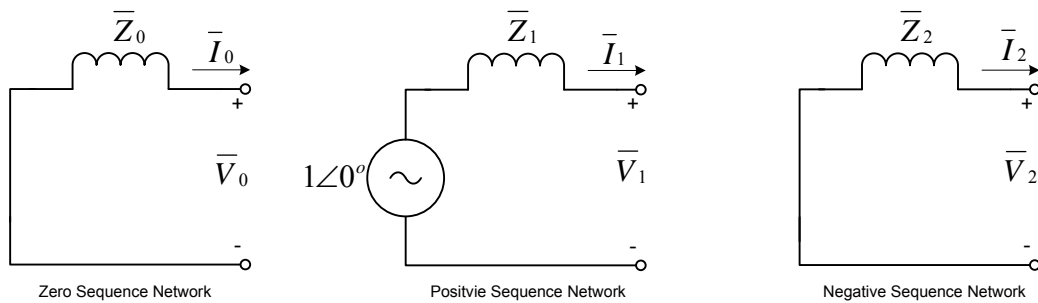

Fig. 8.2

Each of the individual sequence may be considered independently. Since each of the sequence networks involves symmetrical currents, voltages and impedances in the three phases, each of the sequence networks may be solved by the single-phase method. After converting the power system to the sequence networks, the next step is to determine the type of fault desired and the connection of the impedance sequence network for that fault. The network connections are listed in Table 8.1

Table 8.1 - Network Connection

- Three-phase fault - The positive sequence impedance network is only used in three-phase faults. Fig. 8.3
- Single Line-to-Ground fault - The positive, negative and zero sequence impedance networks are connected in series. Fig. 8.5
- Line-to-line fault - The positive and negative sequence impedance networks are connected in parallel. Fig. 8.7
- Double Line-to-Ground fault - All three impedance networks are connected in parallel. Fig. 8.9

The system shown in Fig. 8.1 and simplified to the sequence network in Fig. 8.2 and will be used throughout this section.

Example 8.1

Given $Z_0 = 0.199 \angle 90^\circ pu$, $Z_1 = 0.175 \angle 90^\circ pu$,
 $Z_2 = 0.175 \angle 90^\circ pu$, compute the fault current and
 voltages for a Three-phase fault. Note that the
 sequence impedances are in *per-unit*. This means that
 the solution for current and voltage will be in *per-unit*.

Solution

The sequence networks are interconnected, as shown in
 Fig. 8.3

Note that for a three phase fault, there are no negative
 or zero sequence voltages.

$$V_0 = V_2 = 0$$

$$I_0 = I_2 = 0$$

The current I_1 is the voltage drop across Z_1

$$I_1 = \frac{V_1}{Z_1}$$

$$I_1 = \frac{1 \angle 0^\circ}{j0.175}$$

$$= -j5.71$$

The phase current is converted from the sequence value
 using Eq. (7.8).

$$I_a = 0 - j5.71 + 0 = 5.71 \angle -90^\circ pu$$

$$I_b = 0 + a^2(-j5.71) + a(0) = 5.71 \angle 150^\circ pu$$

$$I_c = 0 + a(-j5.71) + a^2(0) = 5.71 \angle 30^\circ pu$$

Calculating the voltage drop, and referring to Fig. 8.3, the sequence voltages are

$$V_0 = V_2 = 0$$

$$V_1 = 1 \angle 0^\circ - Z_1 I_1$$

$$V_1 = 1 - j0.175(-j5.71) = 0.0$$

$$= 0.0 pu$$

The phase voltages are converted from the sequence
 value using Eq. (7.6).

$$V_a = 0.0 + 0.0 + 0.0 = 0.0 pu$$

$$V_b = 0.0 + a^2(0.0) + a(0.0) = 0.0 pu$$

$$V_c = 0.0 + a(0.0) + a^2(0.0) = 0.0 pu$$

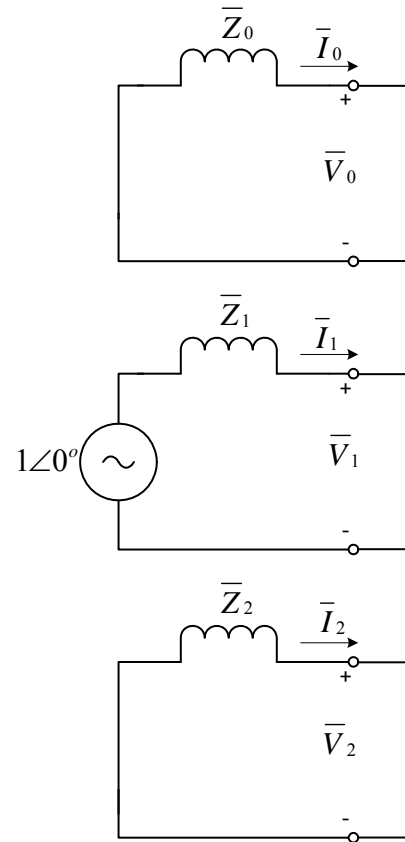

Fig 8.3

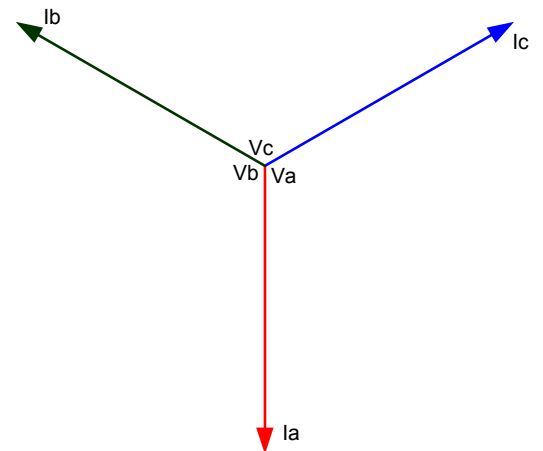

Fig 8.4

The *per-unit* value for the current and voltage would now be converted to actual values using Eq. (5.6b) and knowing the base power and voltage for the given system.

The currents and voltages can be shown in phasor form in Fig. 8.4

Example 8.2

Given $Z_0 = 0.199 \angle 90^\circ pu$, $Z_1 = 0.175 \angle 90^\circ pu$, $Z_2 = 0.175 \angle 90^\circ pu$, compute the fault current and voltages for a Single line-to-ground fault. Note that the sequence impedances are in *per-unit*. This means that the results for current and voltage will be in *per-unit*.

Solution

The sequence networks are interconnected in series, as shown in Fig. 8.5

Because the sequence currents are in series, and using ohms law.

$$I_0 = I_1 = I_2$$

$$I_0 = \frac{V_1}{(Z_0 + Z_1 + Z_2)}$$

$$I_0 = \frac{1 \angle 0^\circ}{(j0.199 + j0.175 + j0.175)}$$

$$= -j1.82 pu$$

The phase currents are converted from the sequence value using Eq. (7.8). Substituting $I_0 = I_1 = I_2$ into Eq. (7.8) gives

$$I_a = I_0 + I_0 + I_0 = 3I_0$$

$$I_b = I_0 + a^2 I_0 + a I_0 = 0$$

$$I_c = I_0 + a I_0 + a^2 I_0 = 0$$

Refer to Table 3.2: $(1 + a + a^2 = 0)$

Note that $I_a = 3I_0$. This is the quantity that the relay “see’s” for a Single Line-to-Ground fault.

Substituting $I_0 = -j1.82 pu$

$$I_a = 3I_0 = 3(-j1.82)$$

$$= -j5.46 pu$$

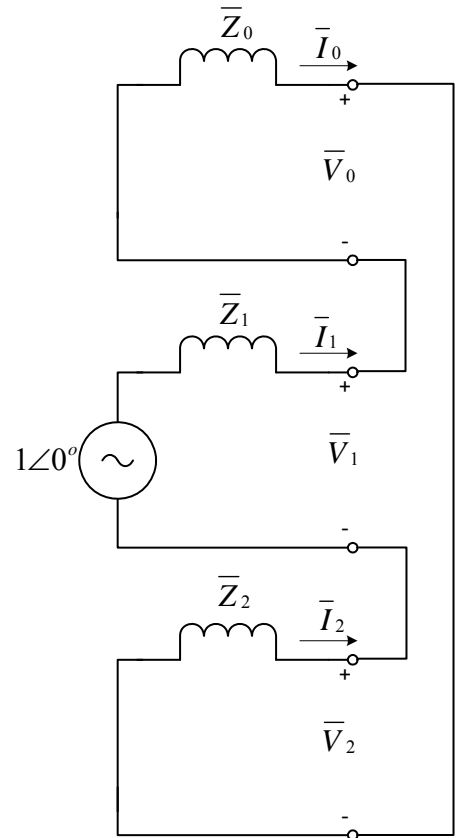

Fig 8.5

Calculating the voltage drop, and referring to Fig. 8.5, the sequence voltages are

$$V_0 = -Z_0 I_0$$

$$V_1 = V - Z_1 I_1$$

$$V_2 = -Z_2 I_2$$

Substituting in the impedance and current from above

$$V_0 = -j0.199(-j1.82) = -0.362$$

$$V_1 = 1 - j0.175(-j1.82) = 0.681$$

$$V_2 = -j0.175(-j1.82) = -0.319$$

The phase voltages are converted from the sequence value using Eq. (7.6).

$$V_a = -0.362 + 0.681 - 0.319 = 0$$

$$V_b = -0.362 + a^2(0.681) + a(-0.319) = 1.022 \angle 238^\circ \text{ pu}$$

$$V_c = -0.362 + a(0.681) + a^2(-0.319) = 1.022 \angle 122^\circ \text{ pu}$$



Fig 8.6

The *per-unit* value for the current and voltage could now be converted to actual values using Eq. (5.6b) and knowing the base power and voltage for the given system.

The currents and voltages can be shown in phasor form in Fig. 8.6

Example 8.3

Given $Z_0 = 0.199 \angle 90^\circ \text{ pu}$, $Z_1 = 0.175 \angle 90^\circ \text{ pu}$, $Z_2 = 0.175 \angle 90^\circ \text{ pu}$, compute the fault current and voltages for a Line-to-Line fault. Note that the sequence impedances are in *per-unit*. This means that the solution for current and voltage will be in *per-unit*.

Solution

The sequence networks are interconnected, as shown in Fig. 8.7

Because the sequence currents sum to one node, it follows that

$$I_1 = -I_2$$

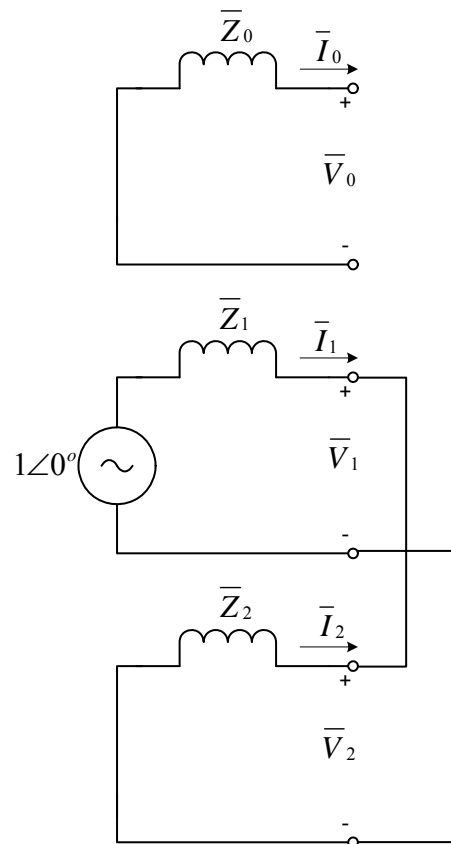

Fig 8.7

The current I_1 is the voltage drop across Z_1 in series with Z_2

$$I_1 = \frac{V_1}{Z_1 + Z_2}$$

$$I_1 = \frac{1\angle 0^\circ}{j0.175 + j0.175}$$

$$= -j2.86 pu$$

$$I_2 = +j2.86 pu$$

$$I_0 = 0$$

The phase current is converted from the sequence value using Eq. (7.8).

$$I_a = 0 - j2.86 + j2.86 = 0 pu$$

$$I_b = 0 + a^2(-j2.86) + a(j2.86) = -4.95 pu$$

$$I_c = 0 + a(-j2.86) + a^2(j2.86) = 4.95 pu$$

Calculating the voltage drop, and referring to Fig. 8.7, the sequence voltages are

$$V_1 = V_2$$

$$V_2 = -Z_2 I_2$$

$$= -(j1.75)(j2.86)$$

$$= 0.5 pu$$

$$V_0 = 0$$

The phase voltages are converted from the sequence value using Eq. (7.6).

$$V_a = 0.0 + 0.5 + 0.5 = 1.0 pu$$

$$V_b = 0.0 + a^2(0.5) + a(0.5) = -0.5 pu$$

$$V_c = 0.0 + a(0.5) + a^2(0.5) = -0.5 pu$$

The *per-unit* value for the current and voltage would now be converted to actual values using Eq. (5.6b) and knowing the base power and voltage for the given system.

The currents and voltages can be shown in phasor form in Fig. 8.8

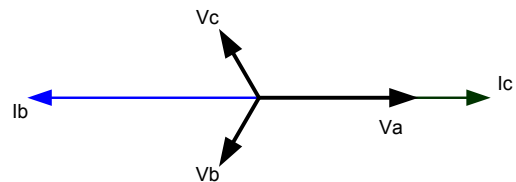

Fig 8.8

Example 8.4

Given $Z_0 = 0.199 \angle 90^\circ pu$, $Z_1 = 0.175 \angle 90^\circ pu$, $Z_2 = 0.175 \angle 90^\circ pu$, compute the fault current and voltages for a Double Line-to-Ground fault. Note that the sequence impedances are in *per-unit*. This means that the solution for current and voltage will be in *per-unit*.

Solution

The sequence networks are interconnected, as shown in Fig. 8.9

Because the sequence currents sum to one node, it follows that

$$I_1 = -(I_0 + I_2)$$

The current I_1 is the voltage drop across Z_1 in series with the parallel combination of Z_0 and Z_2

$$I_1 = \frac{V_1}{Z_1 + \left(\frac{Z_0 Z_2}{Z_0 + Z_2} \right)}$$

Substituting in $V_1 = 1 \angle 0^\circ$, and Z_0 , Z_1 , and Z_2 , then solving for I_1

$$I_1 = -j3.73 pu$$

$$I_0 = \frac{Z_2}{(Z_0 + Z_2)} I_1$$

$$= +j1.75$$

$$I_2 = \frac{Z_0}{(Z_0 + Z_2)} I_1$$

$$= +j1.99$$

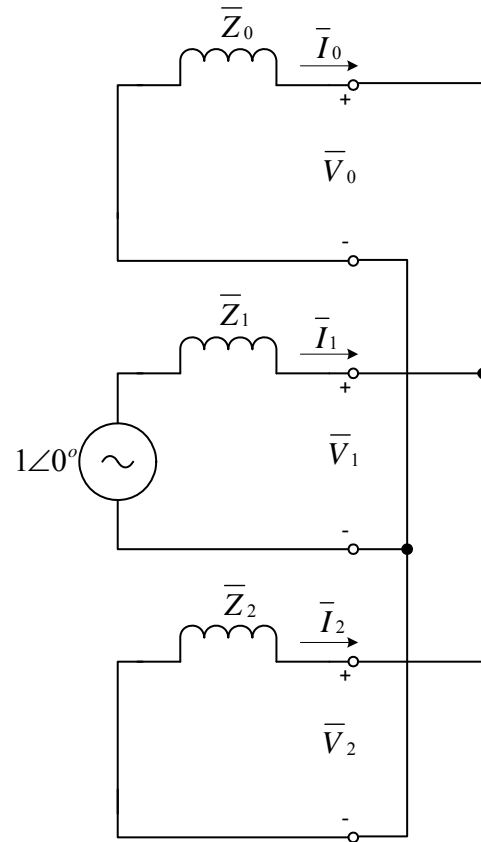

Fig 8.9

The phase current is converted from the sequence value using Eq. (7.8).

$$I_a = j1.75 - j3.73 + j1.99 = 0 pu$$

$$I_b = j1.75 + a^2(-j3.73) + a(j1.99) = 5.60 \angle 152.1^\circ pu$$

$$I_c = j1.75 + a(-j3.73) + a^2(j1.99) = 5.60 \angle 27.9^\circ pu$$

Calculating the voltage drop, and referring to Fig. 8.9, the sequence voltages are

$$\begin{aligned} V_0 &= V_1 = V_2 \\ V_0 &= -Z_0 I_0 \\ &= -(j1.75)(j0.199) \\ &= 0.348 pu \end{aligned}$$

The phase voltages are converted from the sequence value using Eq. (7.6).

$$\begin{aligned} V_a &= 0.348 + 0.348 + 0.348 = 1.044 pu \\ V_b &= 0.348 + a^2(0.348) + a(0.348) = 0 pu \\ V_c &= 0.348 + a(0.348) + a^2(0.348) = 0 pu \end{aligned}$$

Refer to Table 3.2: $(1 + a + a^2 = 0)$

The *per-unit* value for the current and voltage would now be converted to actual values using Eq. (5.6b) and knowing the base power and voltage for the given system.

The currents and voltages can be shown in phasor form in Fig. 8.10

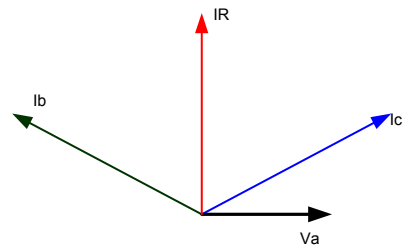

Fig 8.10

9. Oscillograms and Phasors

Attached are four faults that were inputted into a relay and then captured using the relay software.

Three-phase fault. Compare to example (8.1)

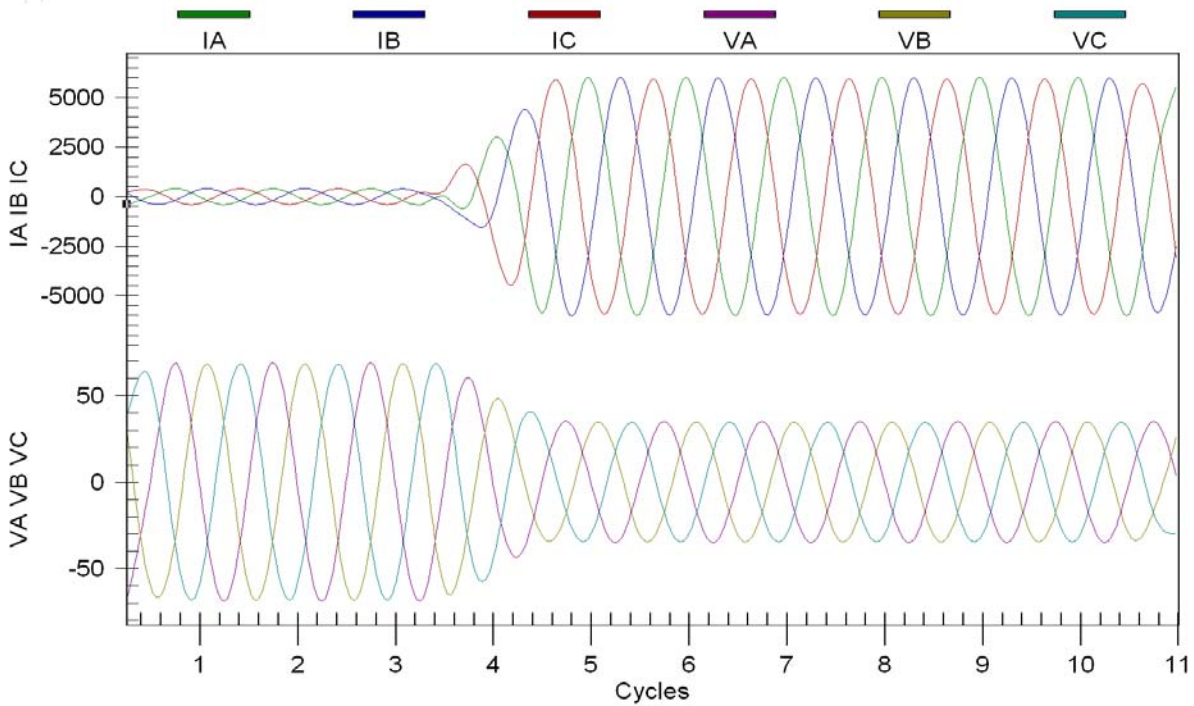

Fig 9.1a

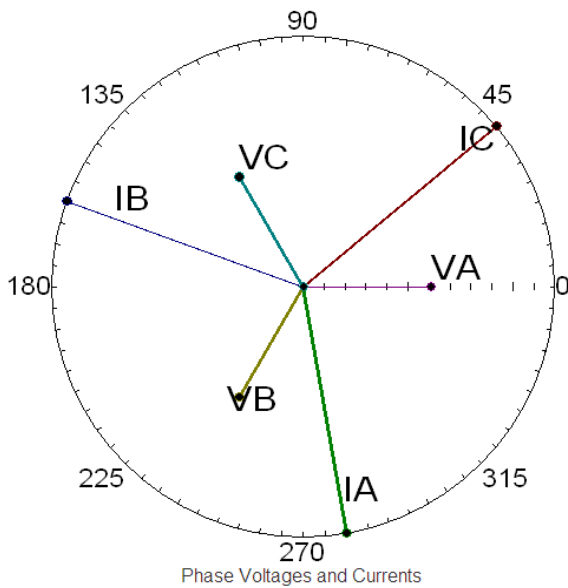

Fig 9.1b

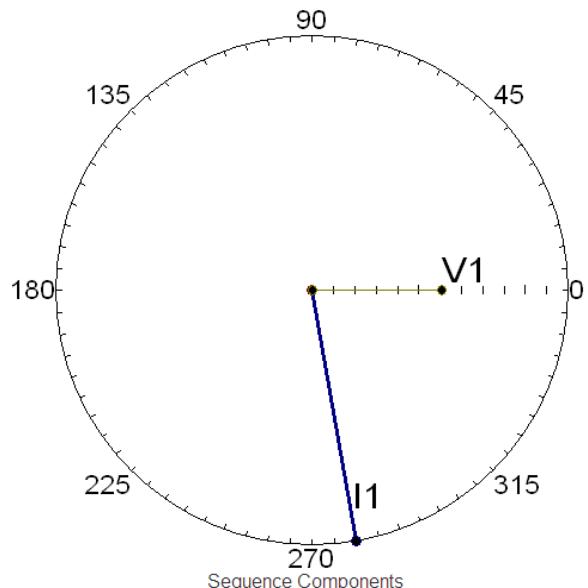

Fig 9.1c

Single Line-to-Ground fault. Compare to example (8.2)

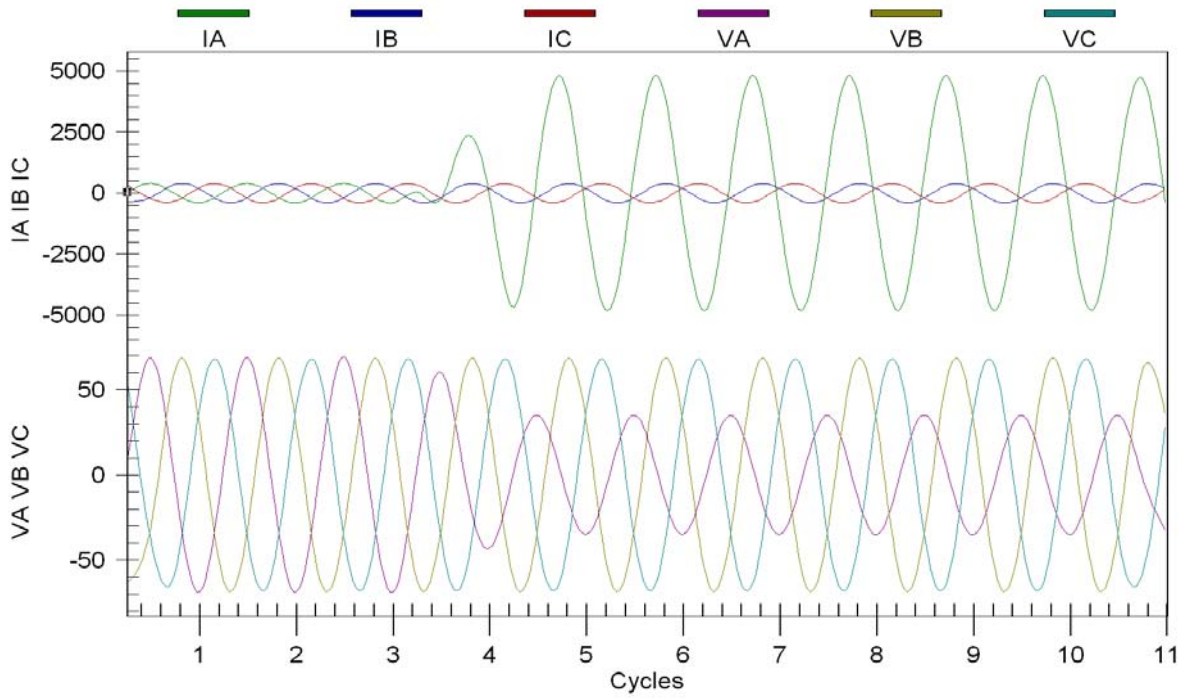
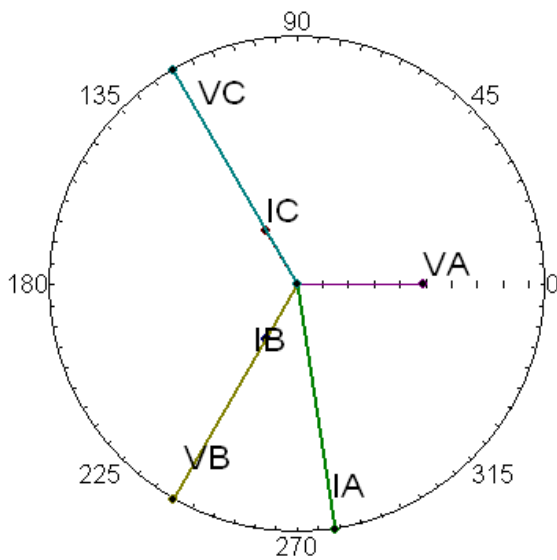
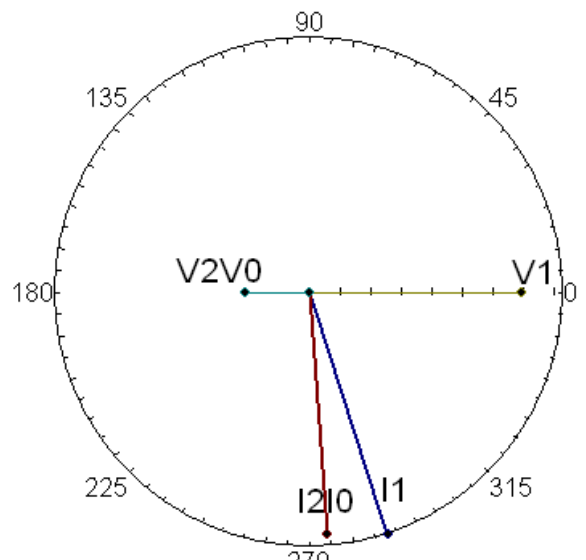

Fig 9.2a



Phase Voltages and Currents

Fig 9.2b



Sequence Components

Fig 9.2c

Line-to-Line fault. Compare to example (8.3)

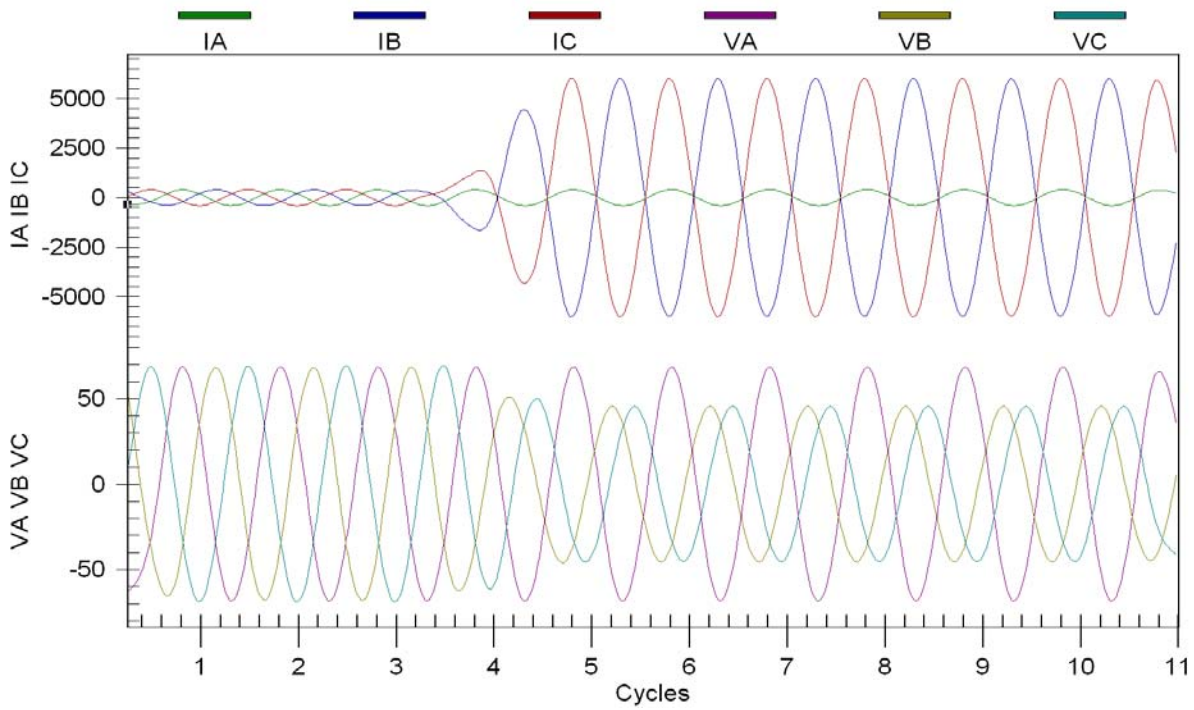
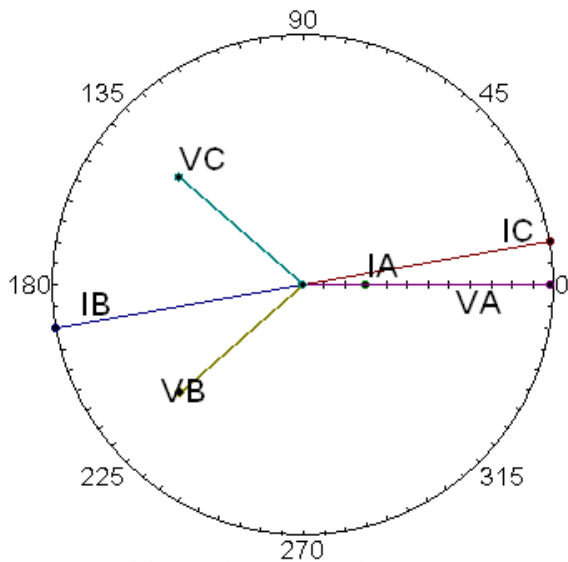
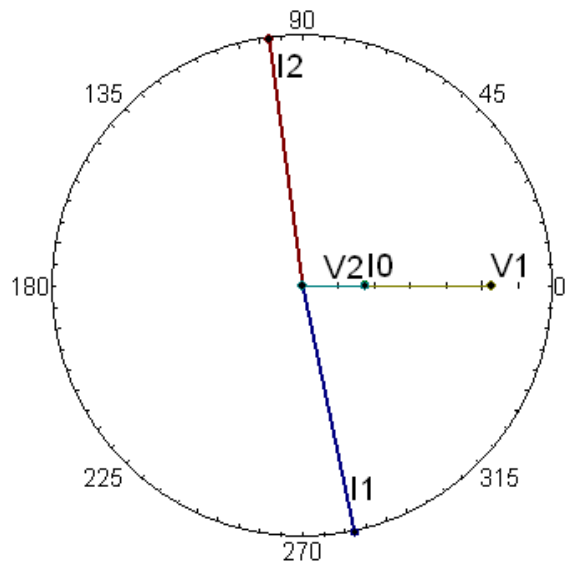

Fig 9.3a



Phase Voltages and Currents

Fig 9.3b



Sequence Components

Fig 9.3c

Double Line-to-Ground fault. Compare to example (8.4)

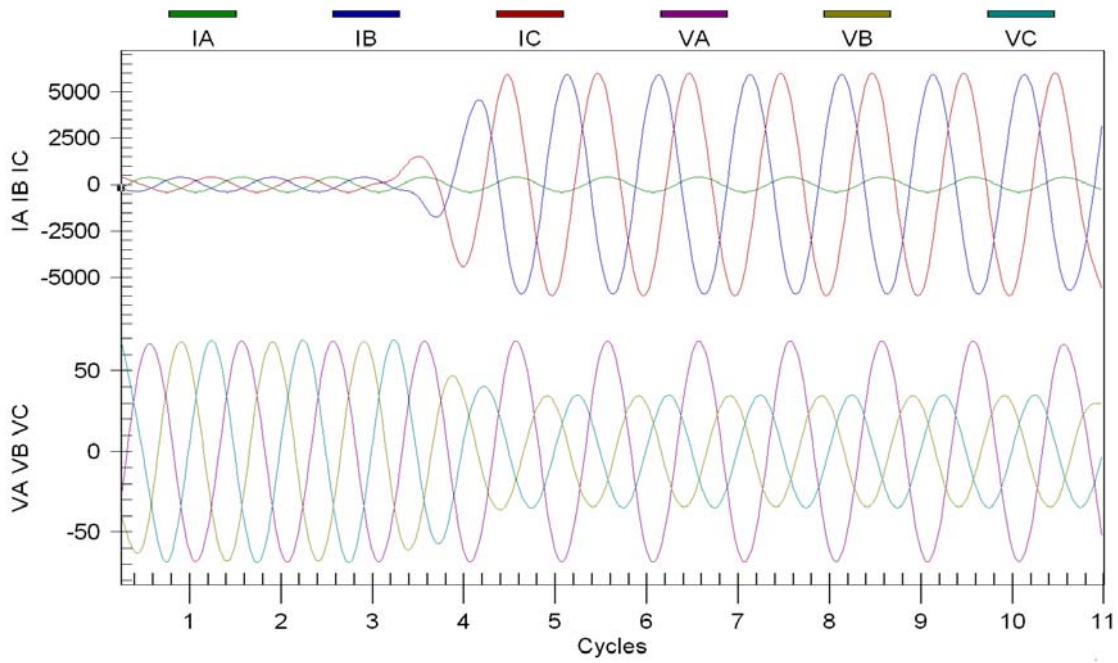
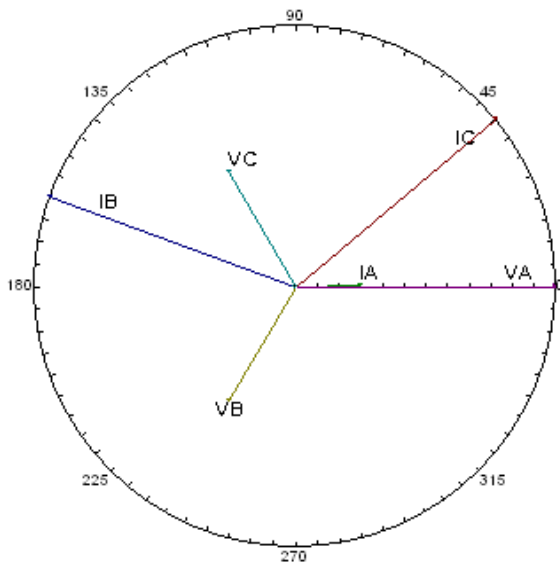
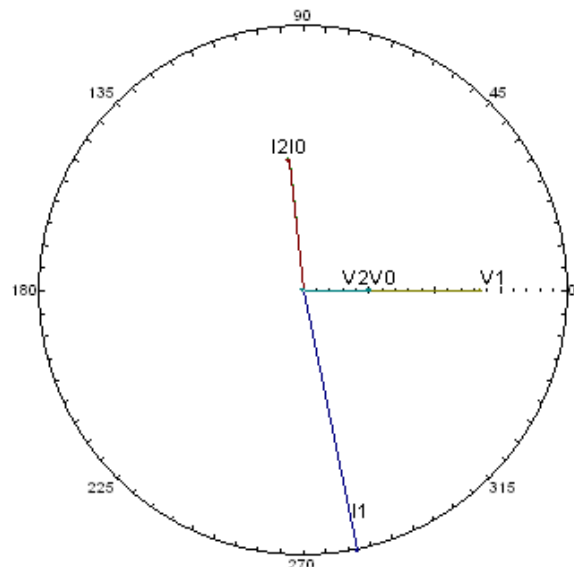

Fig 9.1a



Phase Voltages and Currents
Fig 9.4b



Sequence Components
Fig 9.4c

10. Symmetrical Components into a Relay

Using a directional ground distance relay it will be demonstrated how sequential components are used in the line protection. To determine the direction of a fault, a directional relay requires a reference against which the line current can be compared. This reference is known as the polarizing quantity. Zero sequence line current can be referenced to either zero sequence current or zero sequence voltage, or both may be used. The zero sequence line current is obtained by summing the three-phase currents. See Fig. 10.1

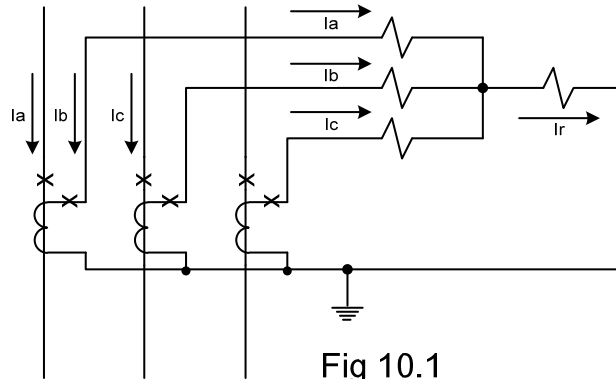

Fig 10.1

From Eq. (7.9)

$$(I_a + I_b + I_c) = 3I_0 = I_r \quad (10.1)$$

This is known as the residual current or simply $3I_0$.

The zero sequence voltage at or near the bus can be used for directional polarization. The polarizing zero sequence voltage is obtained by adding an auxiliary potential transformer to the secondary voltage. The auxiliary transformer is wired as a broken-delta and the secondary inputted to the relay. See Fig 10.2

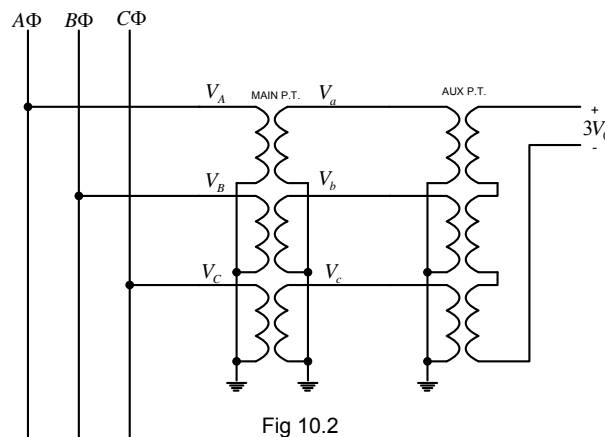

Fig 10.2

From Eq. (7.7) the zero sequence voltage equals

$$V_0 = \frac{1}{3}(V_a + V_b + V_c) \quad (10.2a)$$

$$3V_0 = (V_a + V_b + V_c) \quad (10.2a)$$

Example 10.1

Using the values obtained from example 8.2, calculate $3V_0$.

Solution

$$V_a = 0$$

$$V_b = 1.022 \angle 238^\circ \text{ pu}$$

$$V_c = 1.022 \angle 122^\circ \text{ pu}$$

$$\begin{aligned} 3V_0 &= 0 + 1.022 \angle 238^\circ + 1.022 \angle 122^\circ \\ &= 3.25 \angle 180^\circ \text{ pu} \end{aligned}$$

The zero sequence voltage is $3.25 \angle 180^\circ \text{ pu}$. By connecting the value in the reverse gives $-3V_0$ which equals $3.25 \angle 0^\circ \text{ pu}$. Plotting this, we can show in phasor form what the relay see's, I_a lagging $-3V_0$ by the line angle. In this case resistance is neglected, therefore I_a lags by 90° . (see Fig 10.3).

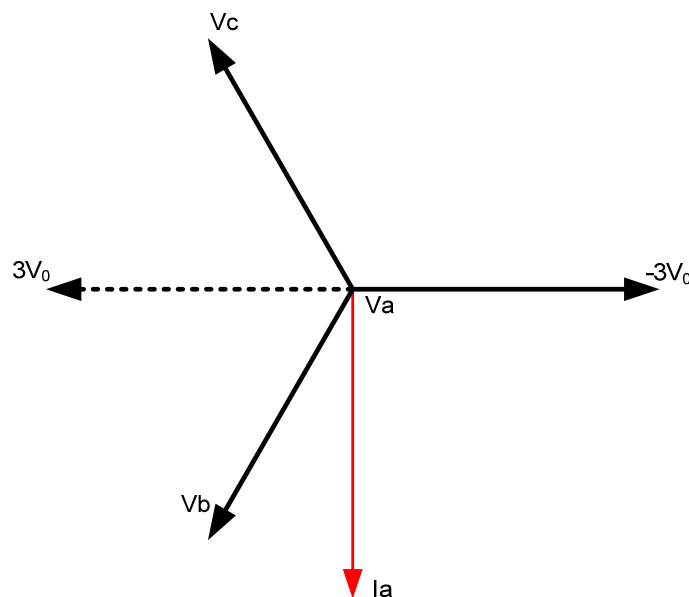

Fig 10.3

References

Blackburn, J. L., Protective Relaying: Principles and Applications, Mercel Dekker, Inc., New York, 1987

Gross, Charles A., Power System Analysis, John Wiley & Sons, Inc., 1986

ABB, Protective Relaying Theory and Applications, Mercel Dekker, Inc., New York, 2004

Wagner, C. F. and Evans, R. D., Symmetrical Components, Krieger Publishing Company, Florida, 1933

Lantz, Martin J., Fault Calculations for Relay Engineers, Bonneville Power Administration, 1965